



Xerxes Wania
CEO



Embedded OTP Solution



- Embedded NVM IP for standard logic CMOS processes
- One-time programmable (OTP) and emulated Multi-time programmable
- No additional masks or processing steps
- Available in 0.18um, 0.13um, 0.11um, 90nm, 80nm, 65nm & below
- OTP Solution

– **SiFuse** – Low bit-count fuse-replacement

– **SiPROM** - High bit-count Flash, EEPROM, Mask ROM replacement



Target Markets



- Mature Segments

- Music - Digital Radios, MP3 players, DARs
- Video - DTV, Home Video Gateways, Still Cameras, Camcorders, DVRs, LCD Displays
- Wireless - Modems, Cell Phones, Pagers
- Other - Game Terminals & Consoles, Dictionaries, Organizers, Directories, Printers, Faxes, Smart Cards, Remote Keyless Entry (RKE), Automotive

- Emerging Segments

- Wireless - UWB and WiMAX
- Encryption - Crypto-Key Storage
- Tracking - Chip or Unique Identification, RFID
- Electronic Advertising – Marketing, Messaging
- Secure Music and Video Delivery – Blu-Ray, HD DVD
- Smart Toys



Product Features



- High Density – up to 8 Mbits
- Fast Access Times – read speed < 10ns
- Field Programmable – wafer/pkg/field
- Low Programming Current – 100s of uA
- Programming Voltage – 5-8.5V
- Short Programming Times – Mbits in secs
- Multiple Time Programming
- Mask ROM Option – single layer
- Scalable – down to 65nm and beyond
- Portable Across Foundries – standard logic CMOS process
- Wide I/O Bus – 8 bits to 512 bits
- Low Power – good for handheld devices
- Option for Wider V and T Operation
- Built-In Redundancy Option – higher yield
- Differential or Single Ended
- Security Features
 - Programmed 1's and 0's look the same
 - No inductive, infrared or magnetic detection
 - No noise signature
 - No charge storage
 - Program lock option



SiFuse Applications (Low Bit Count)



- 128 bits - 64K bits
 - Chip/Secure/RFID – unique identification in every chip; can be used as multi-time programmable cell
 - Memory repair – replace laser fuses
 - Option select – I/O selection replaces mask programming
 - Analog trimming - adjust and trim capacitors and resistors
 - Encryption Key Storage – HDCP, DRM, etc. – very highly secure
- Features
 - Small footprint
 - Wide Data I/O
 - Built-in 100% redundancy
 - Wide operational range
 - Optional multi-time programmable
 - Optional ROM lines

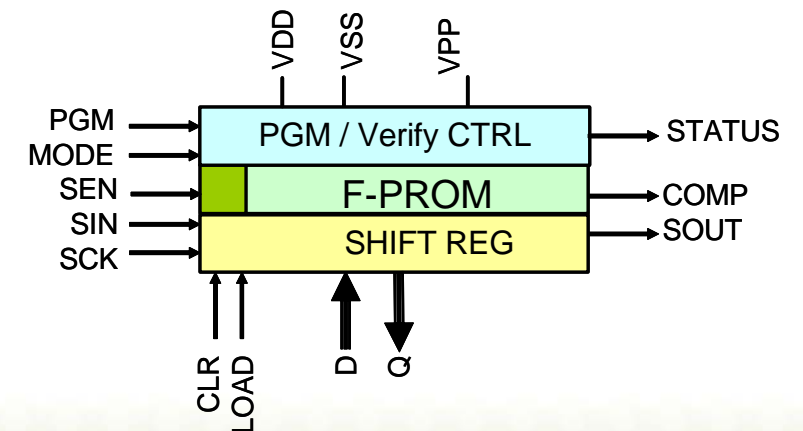

SiPROM Applications (High Bit Count)



- 64Kbits - Megabits
 - Boot and processor code storage – secure boot and code storage
 - Embedded programmable logic – FPGA configuration code
 - Structured ASICs – field programmable and mask programmable
 - Encryption Key Storage – multiple time programmable

- Features

- Fast Read
- Fast Parallel Programming
- Wide I/O
- Low Power – Multi Bank, Multi Sector
- Built-in Redundancy
- ROM migration path (single mask)
- Compiled macros
 - 64Kbit to 4Mbit
 - PROM/ROM hybrid

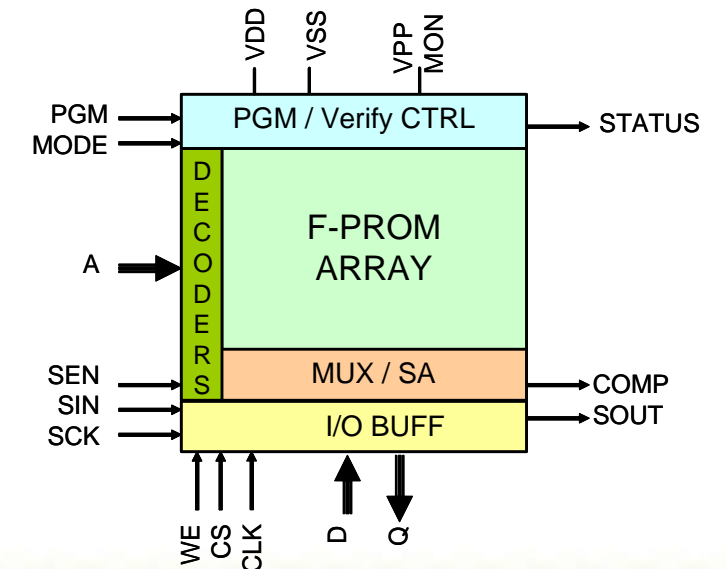

Thank you!



- Please stay and talk with Xerxes
- Explore Sidense IP at ChipEstimate.com
- Use Sidense IP to Plan a Chip at DAC (get a DAC Trip Report!)

